

INSTRUMENTATION ENGINEERING

MEASUREMENTS



Comprehensive Theory
with Solved Examples and Practice Questions





MADE EASY Publications Pvt. Ltd.

Corporate Office: 44-A/4, Kalu Sarai (Near Hauz Khas Metro Station), New Delhi-110016 | **Ph. :** 9021300500

Email : infomep@madeeasy.in | **Web :** www.madeeasypublications.org

Measurements

Copyright © by MADE EASY Publications Pvt. Ltd.

All rights are reserved. No part of this publication may be reproduced, stored in or introduced into a retrieval system, or transmitted in any form or by any means (electronic, mechanical, photo-copying, recording or otherwise), without the prior written permission of the above mentioned publisher of this book.



MADE EASY Publications Pvt. Ltd. has taken due care in collecting the data and providing the solutions, before publishing this book. In spite of this, if any inaccuracy or printing error occurs then **MADE EASY Publications Pvt. Ltd.** owes no responsibility. We will be grateful if you could point out any such error. Your suggestions will be appreciated.

EDITIONS

- First Edition : 2015
- Second Edition : 2016
- Third Edition : 2017
- Fourth Edition : 2018
- Fifth Edition : 2019
- Sixth Edition : 2020
- Seventh Edition : 2021
- Eighth Edition : 2022
- Ninth Edition : 2023
- Tenth Edition : 2024**

CONTENTS

Measurements

CHAPTER 1

Introduction 2-26

1.1	Measurements and its Significance.....	2
1.2	Types of Instruments.....	3
1.3	Deflection and Null Type Instruments.....	3
1.4	Errors in Measurements and their Analysis.....	8
1.5	Types of Errors.....	14
1.6	Analog Instruments.....	15
1.7	Torques in Electromechanical indicating Instruments.....	17
1.8	Types of Damping.....	18
1.9	Errors in Meters.....	20
1.10	Important Prefixes and Their Symbols.....	21
	<i>Objective Brain Teasers</i>	22
	<i>Conventional Brain Teasers</i>	25

CHAPTER 2

Measurement of Resistance..... 27-52

2.1	Resistors.....	27
2.2	Methods of Reducing Residual Inductance and Capacitance in Resistors.....	28
2.3	Measurement of Low Resistance.....	30
2.4	Measurement of Medium Resistance.....	37
2.5	Important Definitions.....	43
2.6	Measurement of High Resistance.....	44
	<i>Objective Brain Teasers</i>	47
	<i>Conventional Brain Teasers</i>	50

CHAPTER 3

A.C. Bridges..... 53-81

3.1	Introduction to Bridge Measurement and A.C. Bridges.....	53
3.2	Measurement of Inductance.....	58
3.3	Wagner Earthing Device.....	71
3.4	Measurement of Frequency.....	72
3.5	Special Bridge Circuit.....	73
	<i>Objective Brain Teasers</i>	76
	<i>Conventional Brain Teasers</i>	79

CHAPTER 4

Electromechanical Indicating Instruments..... 82-124

4.1	Introduction.....	82
4.2	Moving Iron (M.I.) Instruments.....	90
4.3	General Torque Equation of Moving Iron Instruments.....	90
4.4	Errors in Moving Iron Instruments.....	92
4.5	Electrodynamometer Type Instruments.....	99
4.6	Applications of Electrodynamicometer Type Instruments.....	101
	<i>Objective Brain Teasers</i>	116
	<i>Conventional Brain Teasers</i>	119

CHAPTER 5

Measurement of Power and Energy 125-161

5.1	Introduction.....	125
5.2	Measurement of Power.....	125

5.3	Electrodynamometer Wattmeters	126
5.4	Measurement of Energy	146
	<i>Objective Brain Teasers</i>	155
	<i>Conventional Brain Teasers</i>	160

CHAPTER 6

Cathode Ray Oscilloscope (CRO)..... 162-180

6.1	Introduction	162
6.2	Advantages Of CRO.....	162
6.3	Cathode Ray Tube (CRT)	163
6.4	Deflection Sensitivity of CRO.....	166
6.5	Graticule	168
6.6	Relation between Bandwidth and Rise Time	168
6.7	Lissajous Pattern	170
6.8	Phase Angle from the Lissajous Pattern	174
6.9	Special CRO	175
6.10	Probes of CRO	175
	<i>Objective Brain Teasers</i>	176

CHAPTER 7

Instrument Transformers..... 181-199

7.1	Introduction.....	181
7.2	Calculation of Ratio and Phase Angle Error of a CT	185

7.3	Characteristics of Current Transformers	189
7.4	Causes of Errors in CT	190
7.5	Methods to Reduce Errors in CT	191
7.6	Effect of Secondary Open Circuit	192
7.7	Construction of Current Transformer	192
7.8	Equivalent Circuit Diagram of a PT	194
7.9	Errors in a Potential Transformer	195
	<i>Objective Brain Teasers</i>	196
	<i>Conventional Brain Teasers</i>	197

CHAPTER 8

Digital Meters 200-205

8.1	Digital Voltmeter (DVM)	200
8.2	Digital Frequency Meter.....	203

CHAPTER 9

Miscellaneous206-227

9.1	Potentiometer.....	206
9.2	Quality Factor Meter (Q Meter)	212
9.3	Flux Meter.....	218
9.4	Data Acquisition System (DAS)	219
9.5	Telemetry.....	222
	<i>Objective Brain Teasers</i>	225
	<i>Conventional Brain Teasers</i>	227



Introduction to Measurements

Measurement and instrumentation systems have wide applications such as measurement of electrical and physical quantities like current, voltage, power, temperature, pressure, displacement etc.

The need for measurement arises when one wants to generate data for design or when one wants to propose a theory based on a set of measurement and instrumentation for commerce.

The measurement and instrumentation systems can also be used to locate things or events. Like employees present in a building, the epicenter of an earthquake. Sometimes, measurement systems are made a part of control system. One can observe the change in the field of measurement and instrumentation due to the introduction of new standards, and sensors.

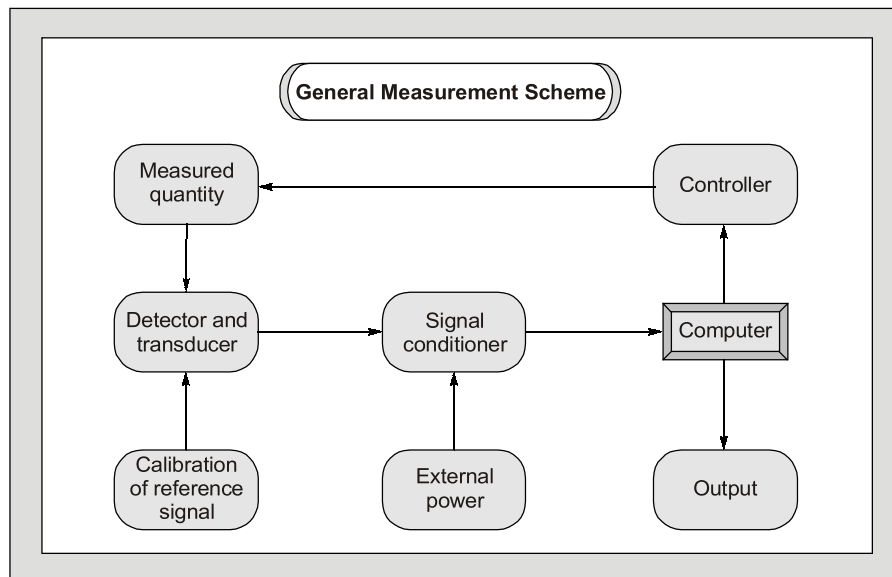

Equal importance has been provided to both theory as well as problems with illustrative examples after every topic. It has been tried to cover every topic so that even a beginner understands it easily to excel in the subject of measurement and instrumentation.



1.1 MEASUREMENTS AND IT'S SIGNIFICANCE

Measurement is the act, or the result, of a quantitative comparison between a given quantity of the same kind chosen as a unit. Measurement result is expressed by a pointer deflection over a predefined scale or a number representing the ratio between the unknown quantity and the standard. The device or instrument used for comparing the unknown quantity with the unity of measurement or a standard quantity is called a measuring instrument.

Method of Measurement

Direct Measurement

- In this method, the measured or the unknown quantity is directly compared against a standard.
- This method of measurement sometimes produces human errors and hence gives inaccurate results.

Indirect Measurement

- This method of measurement is more accurate and more sensitive.
- These are more preferred over direct measurement.

Mechanical, Electrical and Electronic Instruments

Mechanical

- This instruments are used for stable and static conditions:
- They are unable to respond rapidly to measurements of dynamic and transient conditions because of having moving parts that are bulky, heavy are rigid possessing high inertia.

Electrical

Electrical methods of indicating the output of detectors are more rapid than mechanical methods, but they are limited time response.

Electronic

These instruments require use of semiconductor devices. The response time of these instruments are extremely small as a very small inertia of electron is only involved. The sensitivity of these instruments is also very high. Faster response, lower weight, lower power consumption are some of the advantages of electronic instruments.

1.2 TYPES OF INSTRUMENTS

Absolute Instruments : These instruments give the magnitude of the quantity under measurement in terms of physical constants of the instruments, i.e., Tangent Galvanometer, Rayleigh's current balance.

Secondary Instruments : In these type of instruments, the quantity being measured can only be measured by observing the output indicated by the instrument. These instruments are calibrated by comparing with an absolute instrument.

1.3 DEFLECTION AND NULL TYPE INSTRUMENTS

Deflection Type

The deflection of the instrument provides a basis for determining the quantity under measurement, i.e., PMMC Ammeter, Electrodynamicometer and moving iron instruments. They are less accurate, less sensitive and have faster response.

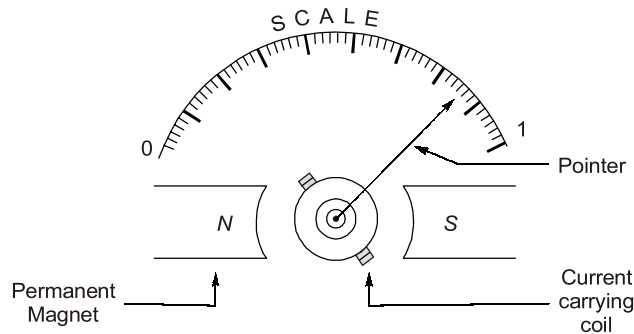

Fig. : PMMC (Deflection Type Instrument)

Null Type Instruments

In null type instruments, a zero or null indication leads to determination of the magnitude of measured quantity. Null type instruments are more accurate, highly sensitive and are less suited for measurements under dynamic conditions than deflection type instruments.

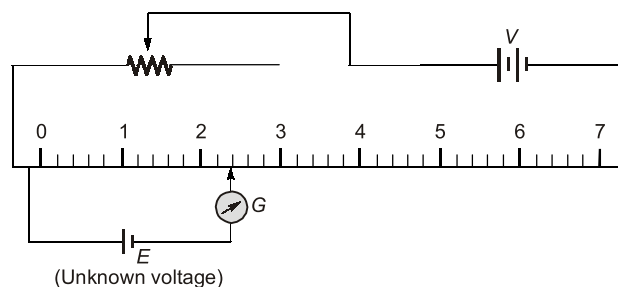

Fig. : Null Type Instrument

Calibration

The calibration of all instruments is important since it affords the opportunity to check the instrument against a known standard and subsequently to find errors and accuracy. Calibration procedures involve a comparison of the particular instrument with a primary standard or, a secondary standard or, an instrument of known accuracy.

Characteristics of Instrument and Measurement Systems

Accuracy

- It is the closeness with which an instrument reading approaches the true value of the quantity being measured.
- The accuracy can be specified in terms of inaccuracy or limits of error.
- The best way to conceive the idea of accuracy is to specify it in terms of the true value of the quantity being measured.
- The accuracy of a measurement means conformity to truth.

Precision

- It is a measure of the reproducibility of the measurements, i.e., given a fixed value of a variable, precision is a measure of the degree to which successive measurements differ from one another.
- The term "Precise" means clearly or sharply defined.
- Precision is used in measurements to describe the consistency or the reproducibility of results.
- Precision instruments are not guaranteed for accuracy.

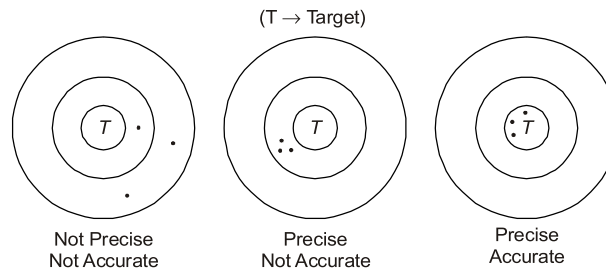

- Precision depends upon number of significant figures.
- The more are significant figures the more is precision.
- Significant figures convey actual information regarding the magnitude and the measurement precision of a quantity.

Example: 302 A (Number of significant figures = 3)

302.10 V (Number of significant figures = 5)

0.000030 Ω (Number of significant figures = 2)

EXAMPLE : 1.1

In calculating voltage drop, a current of 4.37 A is recorded in a resistance of 31.27 Ω . Calculate the voltage drop across the resistor to the appropriate number of significant figures.

Solution :

Current,

$$I = 4.37 \text{ A (3 significant figures)}$$

Resistance,

$$R = 31.27 \Omega \text{ (4 significant figures)}$$

Voltage drop,

$$V = IR = 4.37 \times 31.27 = 136.6499 \text{ volt}$$

Since number of significant figures used in multiplication is 3.

So answer can be written only to a maximum of three significant figures, i.e., $V = 137$

NOTE: 248 volt \Rightarrow 0.000248 MV

248.0 volt \Rightarrow More precised than other two.

EXAMPLE : 1.2

Assertion (A) : A precision instrument is always accurate.

Reason (R) : A precision instrument is one where the degree of reproducibility of the measurements is very good.

- (a) Both A and R are true and R is the correct explanation of A
- (b) Both A and R are true but R is NOT the correct explanation of A
- (c) A is true but R is false
- (d) A is false but R is true

Solution : (d)

Statement (A) is false because accuracy and precision are not interrelated. Accuracy of an instrument is its closeness to the true value.

Statement (R) is correct definition of precision.

Linearity

- If the output is proportional to input then, the instrument is called linear.
- Non-linear behaviour of an instrument doesn't essentially lead to inaccuracy.
- Most of the time it is necessary that measurement system component should have linear characteristics. For example, the resistance used in a potentiometer should vary linearly with displacement of the sliding contact in order that the displacement is directly proportional to the sliding contact voltage. Any departure from linearity will result in error in the reading of system.

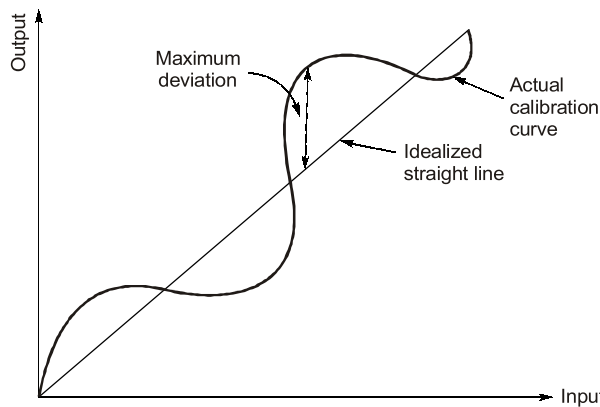

Fig. : Linearity with respect to actual calibration curve and idealized straight line

Drift

Drift is the gradual shift in the indication of the instrument over a period of time. Drift is a undesirable quality in an instruments that is why instruments are properly guarded against it.

Types of Drifts

1. **Zero Drift** : It is the consistent shift across all the measured values. A change in the zero value is responsible for zero drift.
2. **Span Drift** : It is the proportional increasing or decreasing shift of the measured value away from the calibrated values as the measured values increases or decreases.

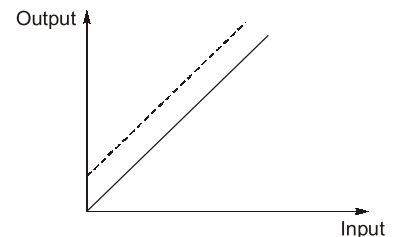

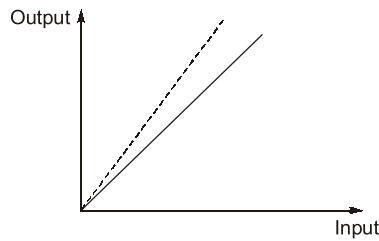

3. **Zonal Drift** : It occurs when only a particular span of measured values is shifted away from the calibrated values. All other measured values remains unaffected.

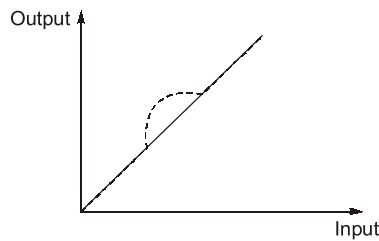

4. **Combined Drift** : When multiple drifts are present at once then combined drift occurs.

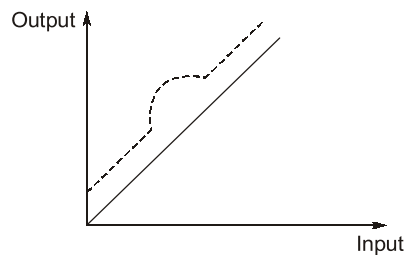

Reproducibility

It is the degree of closeness with which a given value may be repeatedly measured. It may be specified in terms of units for a given period of time.

Static Sensitivity

- The “static sensitivity” of an instrument is the ratio of the magnitude of the output signal or response to the magnitude of input signal or the quantity being measured.
It's units are mm/mA; per volts etc. depending upon type of input and output.
- Sometimes the static sensitivity is expressed as the ratio of the magnitude of the measured quantity to the magnitude of the response.

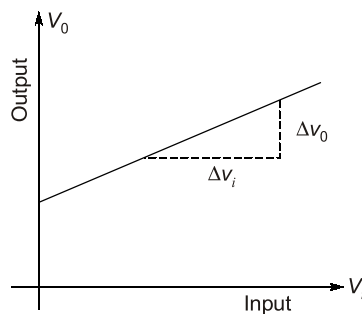

Fig. : Sensitivity

$$\text{Static Sensitivity} = \frac{\text{Small change in output}}{\text{Small change in input}} = \frac{\Delta V_o}{\Delta V_i}$$

- The sensitivity of an instrument should be high and therefore, instrument should not have a range greatly exceeding the value to be measured.

$$\text{Deflection Factor} = \frac{1}{(\text{Static Sensitivity})}$$

Resolution or Discrimination

- The small measurable input change that can be measured by the instrument is called resolution or discrimination.
- If the input is slowly increased from some arbitrary (non-zero) input value, it will again be found that output doesn't change at all until a certain increment is exceeded. This increment is called resolution.

EXAMPLE : 1.3

A digital voltmeter has a read-out range from 0 to 9,999 counts. If the full scale reading is 9.999 V, then the resolution of the instrument in mV, is ____.

Solution :

Resolution of instrument = 1 count in 9,999

$$\text{Resolution} = \frac{1}{9999} \text{ count} = \frac{1}{9999} \times 9.999 = 10^{-3} \text{ volt} = 1 \text{ mV}$$

Dead Time & Dead Zone

Dead Time: The time required for the measurement to begin to respond to the changes in the measurand is known as dead time. It is the time after which the instrument begins to respond after the measured quantity has been changed.

Dead Zone: Dead zone is the largest change of input quantity for which there is no output of the instrument.

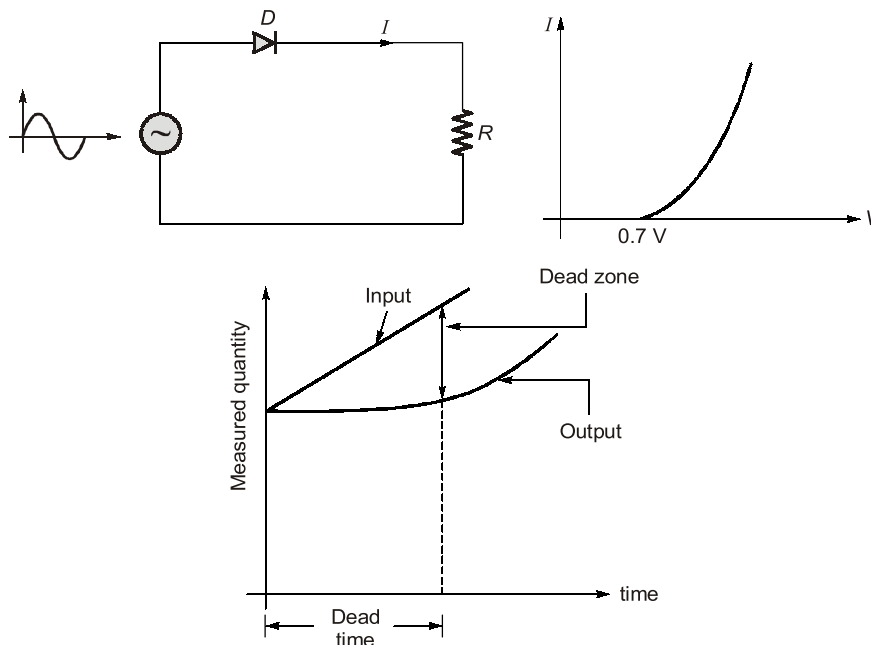

Fig. : Dead Zone and Dead Time



OBJECTIVE BRAIN TEASERS

Q1 Which of the following error is likely to occur in bridge method of measurement?

1. Residual error
2. Frequency and waveform error
3. Leakage and eddy current error

- (a) 1 only (b) 2 only
(c) 1 and 2 only (d) 1, 2 and 3

Q2 A utility type voltmeter with an accuracy of $\pm 3\%$ of full scale (at 25°C) is used on 300 V scale to measure 230 V. What will be the possible percentage error and what range will the actual voltage fall within if the instrument reads 200 V?

- (a) 3.9%, 200 V (b) 3.9%, 191-209 V
(c) 7.6%, 221-239 V (d) 7.6%, 200 V

Q3 In the circuit given in the figure, the limiting error in the power dissipation ' I^2R ' in the resistor R is

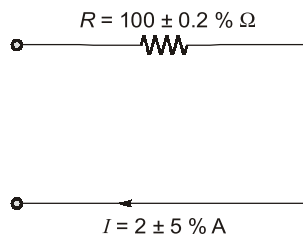

- (a) 1.2% (b) 5.2%
(c) 10.2% (d) 25.2%

Q4 A zero to 300 V voltmeter has a guaranteed accuracy of 1% full scale reading. The voltage measured by the instrument is 83 V. The percentage limiting error is

- (a) 0.95 (b) 1.81
(c) 3.62 (d) 4.85

Q5 Five Students made the following readings on a very accurate voltmeter which reads 2.13 V, 3.15 V, 2.97 V, 3.10 V and 2.99 V. What is the most probable value of the voltage?

- (a) 3.066 V (b) 3.12 V
(c) 2.99 V (d) 2.97 V

Q6 The measurement of a quantity :

- (a) is an act of comparison of an unknown quantity with another quantity.

(b) is an act of comparison of an unknown quantity with a known quantity whose accuracy may be known or may not be known.

(c) is an act of comparison of an unknown quantity with a predefined acceptable standard which is accurately known.

(d) none of the above

Q7 A null type of instrument as compared to a deflection type instrument has

- (a) a high accuracy (b) a lower sensitivity
(c) a faster response (d) all of these

Q8 In measurement systems, which of the following are undesirable static characteristics?

- (a) Sensitivity and accuracy
(b) Drift, static error and dead zone
(c) Reproducibility and non-linearity
(d) Drift, static error, dead zone and non-linearity

Q9 A set of reading has a wide range and therefore it has:

- (a) low precision (b) high precision
(c) low accuracy (d) high accuracy

Q10 The following are the desirable dynamic characteristics of a measurement system :

- (a) fast response, fidelity, measuring lag and dynamic error
(b) fast response and measuring lag
(c) fidelity and measuring lag
(d) fast response and fidelity

Q11 A 0-10 A ammeter has a guaranteed accuracy of 1.5% of full scale reading. The current measured by the instrument is 2.5 A. The percentage limiting error in the measurement is \pm _____ %.

Q12 In the Permanent Magnet Moving Coil (PMMC) instruments, damping is provided by

- (a) The coil spring attached to the moving coil.
(b) The aluminium frame to the moving coil.
(c) Damping vane in the air tight chamber.
(d) Eddy current disk.

Q13 A PMMC instrument is spring controlled. The control spring stiffness decreases by 0.02 percent per degree Celsius rise in temperature and magnetic field strength decreases by 0.01 percent

per degree Celsius rise in temperature. If the rise in temperature is 10° C, the instrument's reading

- (a) decreases by 0.1 percent.
- (b) increases by 0.2 percent.
- (c) increases by 0.1 percent.
- (d) decreases by 0.2 percent.

Q.14 The damping method used in horizontally mounted moving iron instrument is

- (a) Eddy current damping
- (b) Electro magnetic damping
- (c) Fluid friction damping
- (d) Air friction damping

Q.15 A power transformer was tested to determine losses and efficiency. The input power was measured as 3650 W and delivered output power was 3385 W with each reading in doubt by ±10 W. The percentage uncertainty in the losses of the transformer is

- (a) ±4.30%
- (b) ±5.34%
- (c) ±2.24%
- (d) ±10.24%

Q.16 In a gravity controlled instrument the controlling weight is 0.005 kg and acts at distance of 2.4 cm from the axis of the moving system. The deflection in degrees corresponding to deflecting torque of 1.05×10^{-4} Kg-m is

Q.17 The torque of an ammeter varies as the square of the current through it. If a current of 10 A produces a deflection of 90°. The deflection for a current of 5 A when the instrument is gravity controlled, is _____ degrees.

Q.18 The value of capacitance of a capacitor is specified as $1 \mu\text{F} \pm 5\%$ by the manufacturer. The value of limits between which the value of capacitance is guaranteed will be

- (a) 0.98 μF to 1.02 μF
- (b) 0.95 μF to 1.05 μF
- (c) 0.80 μF to 1.20 μF
- (d) 0.90 μF to 1.10 μF

Q.19 A temperature range from -20°C to 50°C is to be measured with a resolution of 0.2°C. The minimum bits required to get a matching dynamic range of the temperature sensor will be

- (a) 8
- (b) 4
- (c) 6
- (d) 9

Q.20 In a ramp type digital voltmeter, the ramp voltage falls from 4 V to 0 V in 10 msec and duration for an applied voltage and the number of pulses counted is 10000. The value of oscillator frequency (in MHz) for above counter will be ____.

Q.21 The input impedance of a CRO is equivalent to a 1 M Ω resistance in parallel with 45 pF capacitance. It is used with a compensated 10 : 1 attenuation probe. The effective input capacitance at the probe tip is

- (a) 4.5 pF
- (b) 5 pF
- (c) 45 pF
- (d) 450 pF

ANSWER KEY

- 1. (d) 2. (b) 3. (c) 4. (c) 5. (a)
- 6. (c) 7. (a) 8. (d) 9. (a) 10. (d)
- 11. (6) 12. (b) 13. (c) 14. (d) 15. (b)
- 16. (61) 17. (14.5) 18. (b) 19. (d) 20. (1)
- 21. (a)

HINTS & EXPLANATIONS

1. (d)

The various errors occurring in bridge method of measurement are (which we will see in later chapters):

- ⇒ Frequency error
- ⇒ Waveform error
- ⇒ Eddy Current error
- ⇒ Leakage Current error
- ⇒ Residual error

2. (b)

Accuracy = ± 3% of full scale which corresponds to ± 9 V. So, range of reading for

$$200 \text{ V} = (200 \pm 9) \text{ V} = 191 - 209 \text{ V}$$

3. (c)

$$\begin{aligned} \% \epsilon &= 2 \times \epsilon_I + \epsilon_R \\ &= 2 \times 5 + 0.2 = 10.2\% \end{aligned}$$

4. (c)

$$1\% \text{ accuracy} = \frac{300 \times 1}{100} = 3 \text{ V}$$

$$\therefore \text{Percentage limiting error} = \frac{8}{83} \times 100 = 3.62\%$$

5. (a)

Most probable value is the mean value.

$$\begin{aligned} \bar{X} &= \left(\frac{3.12 + 3.15 + 2.97 + 3.1 + 2.99}{5} \right) \\ &= 3.066 \text{ V} \end{aligned}$$

7. (a)

Null type instruments have higher accuracy, while deflection instruments are faster.

9. (a)

Since the range of values is more, the repeatability is less, thus the precision is low.

10. (d)

Any lag or error is never desired in any measuring system, especially dynamic.

11. (6)

The Magnitude of the limiting error of instrument

$$\text{is} = \pm \frac{1.5}{100} \times 10 = \pm 0.15 \text{ A}$$

$$\% \text{ Limiting error} = \pm \frac{0.15}{2.5} \times 100 = \pm 6\%$$

12. (b)

The movement induces emf and hence current in the aluminium frame of the coil. The torque developed due to this current is the damping torque.

13. (c)

The change in stiffness of control spring for per degree Celsius rise in temperature = -0.02%

The change in magnetic field strength for per degree Celsius rise in temperature = -0.01%

\therefore The % increase in deflection = $0.02\% - 0.01\% = 0.01\%$

For 10°C rise, the deflection increases = $0.010 \times 10 = 0.1\%$

14. (d)

Air friction damping method is used in horizontally mounted moving iron instruments.

15. (b)

Given : $P_1 = 3650 \text{ W}$, $P_0 = 3385 \text{ W}$

Uncertainties, $W_{pi} = \pm 10 \text{ W}$

$$W_{po} = \pm 10 \text{ W}$$

Losses in transformer,

$$P_L = P_i - P_o = 3650 - 3385 = 265 \text{ W}$$

$$\therefore \frac{\partial P_L}{\partial P_i} = 1, \quad \frac{\partial P_L}{\partial P_o} = -1$$

\therefore Uncertainty in losses

$$= \pm \sqrt{\left(\frac{\partial P_L}{\partial P_i} \right)^2 W_{pi}^2 + \left(\frac{\partial P_L}{\partial P_o} \right)^2 W_{po}^2}$$

$$= \pm \sqrt{(1)^2 (10)^2 + (-1)^2 (10)^2} = \pm 10\sqrt{2}$$

\therefore % uncertainty in loss

$$= \frac{\pm 10\sqrt{2}}{265} \times 100 = \pm 5.34\%$$

16. (61)

Controlling weight, $W = 0.005 \text{ kg}$

Distance of controlling weight from axis of moving system, $l = 2.4 \text{ cm} = 0.024 \text{ m}$

Deflecting torque, $T_d = 1.05 \times 10^{-4} \text{ kg-m}$

Let the deflection corresponding to the given torque is θ

$$1.05 \times 10^{-4} = Wl \sin \theta = 0.005 \times 0.024 \times \sin \theta$$

$$\text{or, deflection, } \theta = \sin^{-1} \left(\frac{1.05 \times 10^{-4}}{0.005 \times 0.024} \right) = 61^\circ$$

17. (14.5)

$$T_e \propto \sin \theta$$

$$\sin \theta \propto I^2$$

$$\text{or, } \frac{\sin \theta_2}{\sin \theta_1} = \left(\frac{I_2}{I_1} \right)^2$$

$$\text{or, } \theta_2 = \sin^{-1} \left[\left(\frac{I_2}{I_1} \right)^2 \sin \theta_1 \right]$$

$$= \sin^{-1} \left[\left(\frac{5}{10} \right)^2 \times 1 \right]$$

$$= \sin^{-1} 0.25 = 14.5^\circ$$

18. (b)

We know, $A_t = A_a(1 \pm \epsilon_r) = 1(1 \pm 0.05)$
 $= 0.95 \mu\text{F to } 1.05 \mu\text{F}$

19. (d)

Given : temperature range $(50^\circ - (-20^\circ)) = 70^\circ\text{C}$
 Resolution = 0.2°C

Resolution relative to range = $\frac{0.2}{70} = 0.00286$

For N bit ADC, Resolution = $\frac{1}{2^N - 1} = 0.00286$

$2^N = 350 \Rightarrow N \approx 9$

20. (1)

The number of pulses counted by ramp type DVM,

$$n = \frac{t_r}{t_{clk}}$$

$t_r = 10 \text{ msec}; n = 10000$

$n = t_r \times f_{clk}$

Oscillator frequency,

$$f_{clk} = \frac{10000}{10 \times 10^{-3}} = 1 \text{ MHz}$$

21. (a)

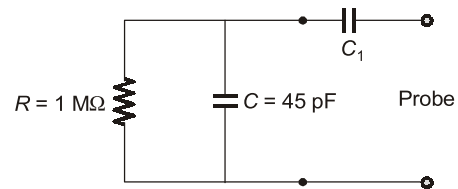

So effective capacitance

$$C_{eq} = \frac{C_1 \cdot C}{C_1 + C} = \frac{C}{10}$$

$\Rightarrow 10C_1 = C_1 + C \Rightarrow C_1 = \frac{C}{9} = \frac{45}{9} = 5 \text{ pF}$

The effective input capacitance at probe tip

$$= \frac{C_1 C}{C_1 + C} = \frac{45 \times 5}{50} = 4.5 \text{ pF}$$



CONVENTIONAL BRAIN TEASERS

Q.1 Find the uncertainty in the measurement of power dissipated by resistor if the current flowing through the resistor is 5 A and the voltage across the resistor is 200 V and the uncertainty of the ammeter is 0.2 A and the voltmeter is 1.5 V. Find the uncertainty of the power.

1. (Sol)

We know that,

$P = VI$

\therefore

$\frac{\delta P}{\delta V} = I = 5 \text{ A}$

$W_V = 1.5 \text{ V}$

(given)

$\frac{\delta P}{\delta I} = V = 200 \text{ V},$

$W_I = 0.2 \text{ A}$

\therefore Uncertainty in the measurement of power is given by :

$$W_P = \sqrt{\left(\frac{\delta P}{\delta V}\right)^2 \cdot W_V^2 + \left(\frac{\delta P}{\delta I}\right)^2 \cdot W_I^2}$$

$$= \sqrt{(200)^2 \times 0.2^2 + (5)^2 \times 1.5^2} = 40.69 \text{ watt}$$

∴ Uncertainty in the measurement of power = 40.69 watt.

Q2 A circuit was tuned for resonance by eight different students, and the values of resonant frequency in kHz were recorded as 532, 548, 543, 535, 546, 531, 543 and 536.

Calculate :

- (a) the arithmetic mean (b) deviations from mean
(c) the average deviation (d) the standard deviation, and
(e) variance

2. (Sol)

(a) The arithmetic mean of readings is given by

$$\bar{X} = \frac{\sum x}{n} = \left(\frac{532 + 548 + 543 + 535 + 546 + 531 + 543 + 536}{8} \right) = 539.25 \text{ kHz}$$

(b) The deviations are :

$$d_1 = x_1 - \bar{X} = 532 - 539.25 = -7.25 \text{ kHz ;}$$

$$d_2 = x_2 - \bar{X} = 548 - 539.25 = +8.75 \text{ kHz}$$

$$d_3 = x_3 - \bar{X} = 543 - 539.25 = +3.75 \text{ kHz ;}$$

$$d_4 = x_4 - \bar{X} = 535 - 539.25 = -4.25 \text{ kHz ;}$$

$$d_5 = x_5 - \bar{X} = 546 - 539.25 = +6.75 \text{ kHz ;}$$

$$d_6 = x_6 - \bar{X} = 531 - 539.25 = -8.25 \text{ kHz}$$

$$d_7 = x_7 - \bar{X} = 543 - 539.25 = +3.75 \text{ kHz ;}$$

$$d_8 = x_8 - \bar{X} = 536 - 539.25 = -3.25 \text{ kHz}$$

(c) Average deviation is given by

$$\bar{D} = \frac{\sum |d|}{n} = \left(\frac{7.25 + 8.75 + 3.75 + 4.25 + 6.75 + 8.25 + 3.75 + 3.25}{8} \right) = 5.75 \text{ kHz}$$

(d) Since the number of observations are 8 which is less than 20, therefore, the standard deviation will be given by

$$S = \sqrt{\frac{\sum d^2}{(n-1)}}$$

$$= \sqrt{\frac{(-7.25)^2 + (+8.75)^2 + (3.75)^2 + (-4.25)^2 + (+6.75)^2 + (-8.25)^2 + (3.75)^2 + (3.25)^2}{(8-1)}}$$

$$= 6.54 \text{ kHz}$$

(e) Variance = $S^2 = 42.77 \text{ (kHz)}^2$

